

Low-Cost Experiments in STEM Education



Alan Casey | Coláiste an Chroí Naofa | Cork | Ireland

FROM STATIC TO LIGHT

Let's illuminate the charge.

A set of hands-on activities that guide students through the concept of static electricity emphasising how static electricity can be transformed into a viable source of energy by constructing a Triboelectric Nanogenerator (TEMG) - capable of powering an LED.

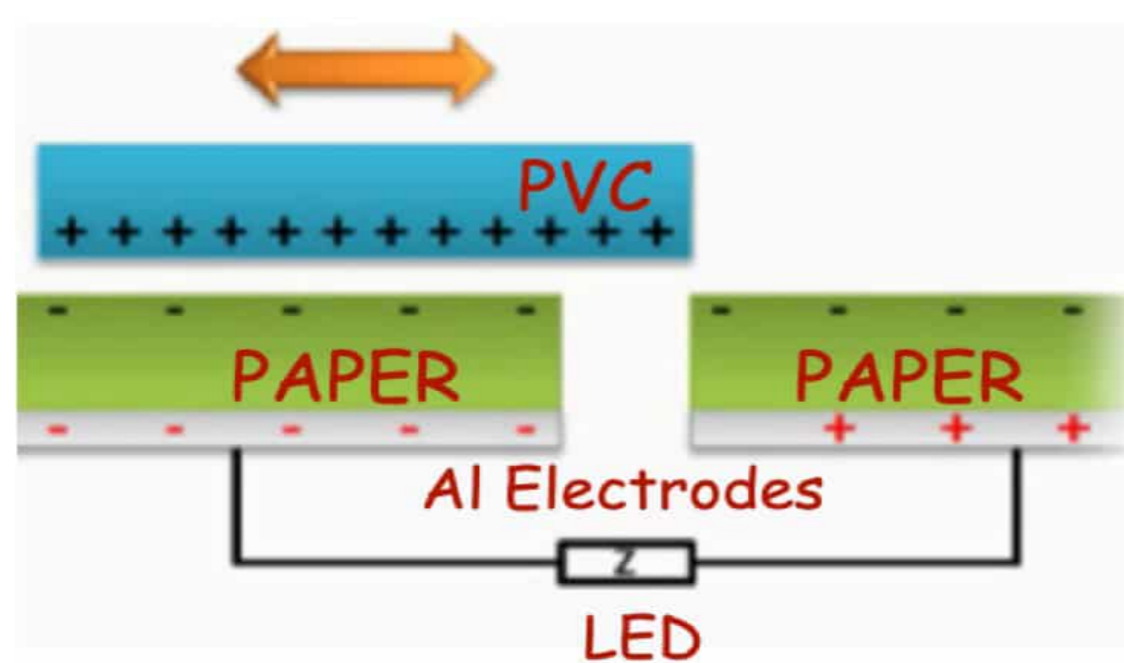

Triboelectric Nanogenerators (TEMGs) operate on the principle of the triboelectric effect, where specific materials become charged upon contact with others, effectively converting mechanical energy into electrical energy.

Students follow a path that includes:

- Exploring Static Electricity: Electron transfer and charge creation via material friction and Induced charges.
- The Triboelectric Series: Experiment with material combinations to understand electron affinity.
- Build and Test: TEMGs of different geometries and actions(tapping, sliding and shaking) are built and their output is measured.
- Illumination: Direct conversion of mechanical energy into light.

Conclusion: Students of all ages (12-18) engaged in this activity: Creating a generator out of cheap everyday materials that does not involve a magnet and coil and using it to light an LED.

MATERIALS

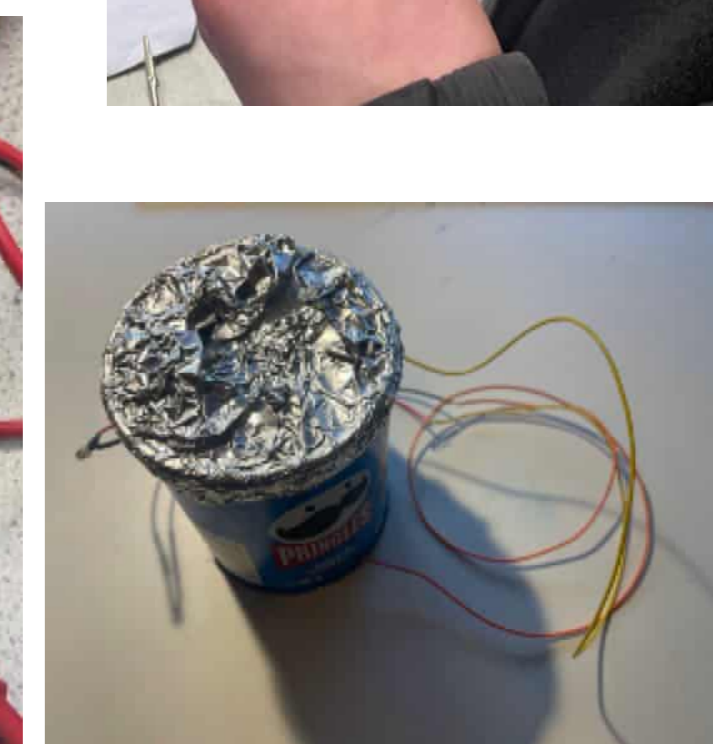
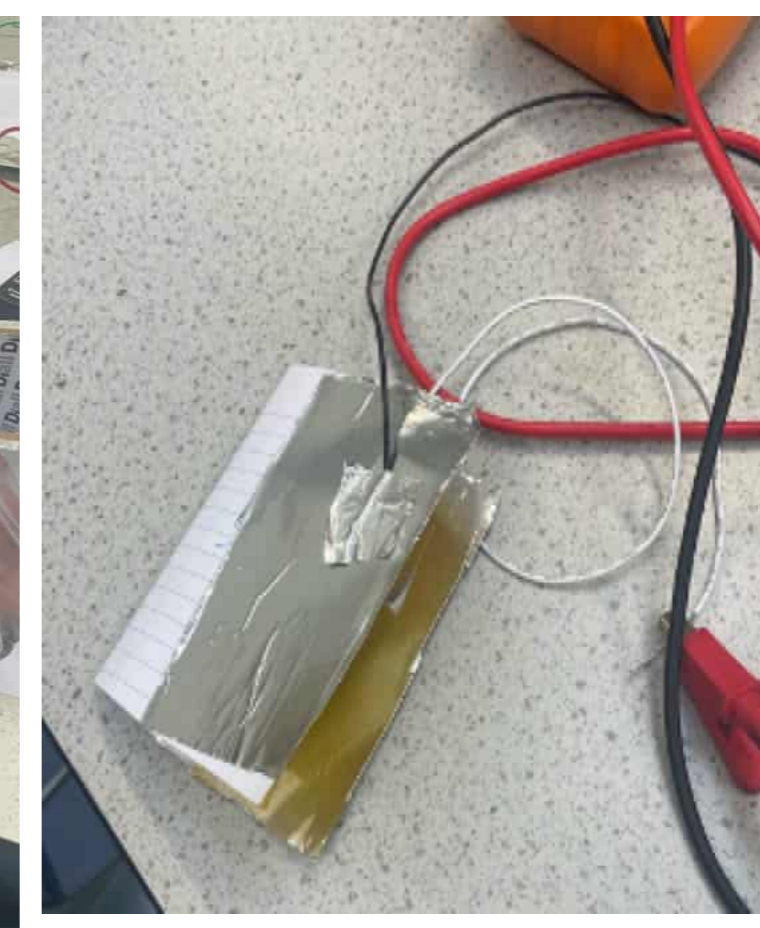
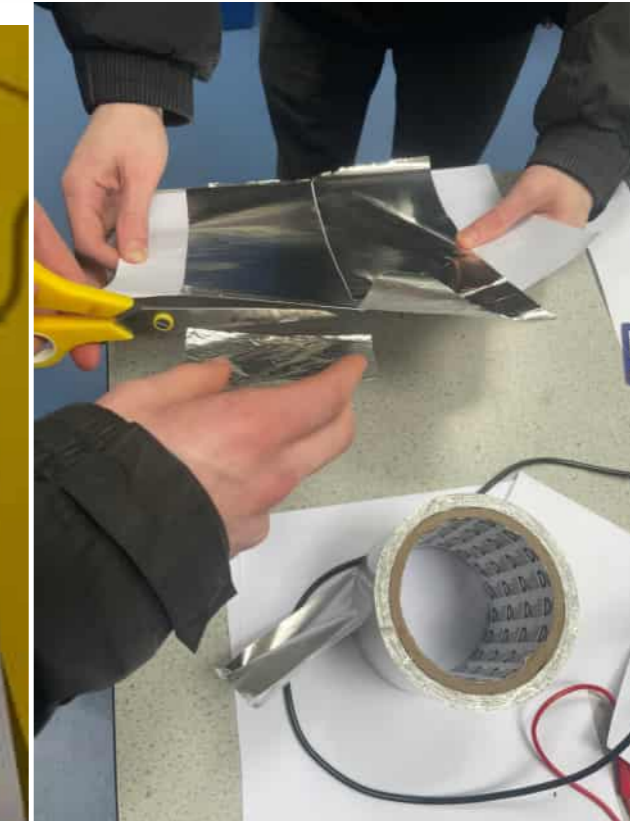
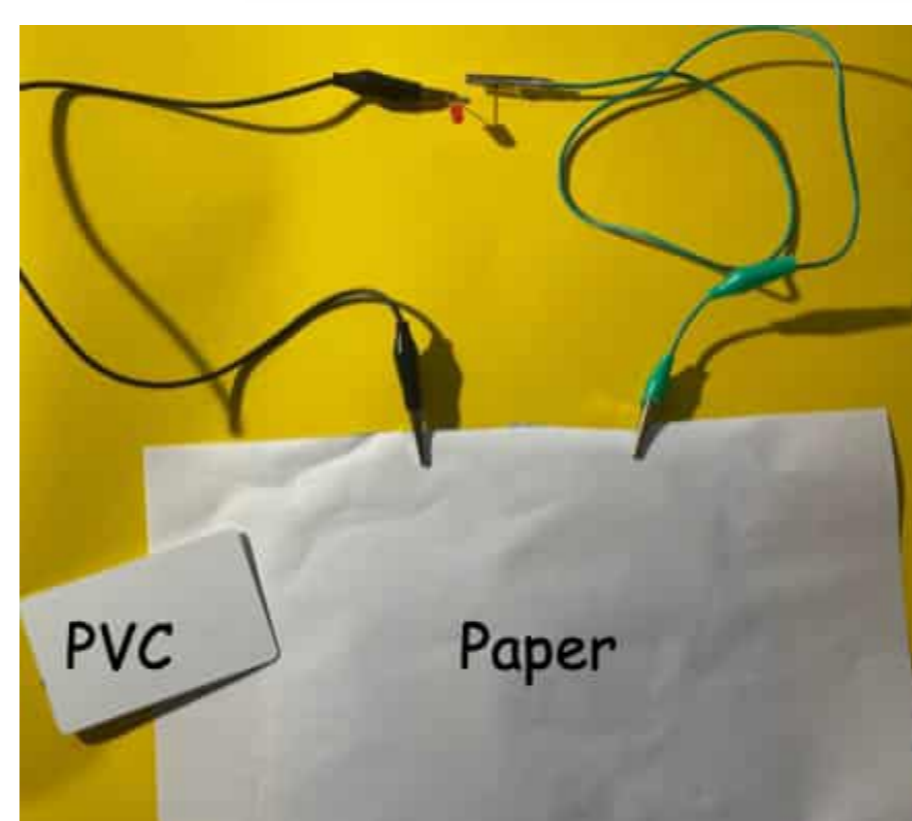
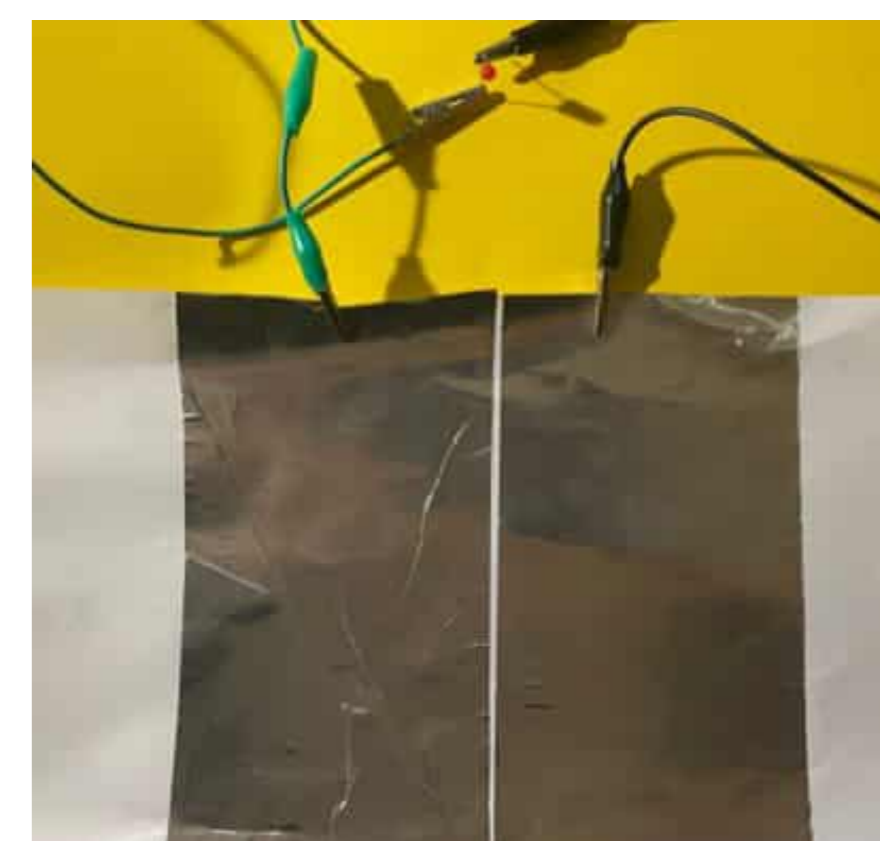
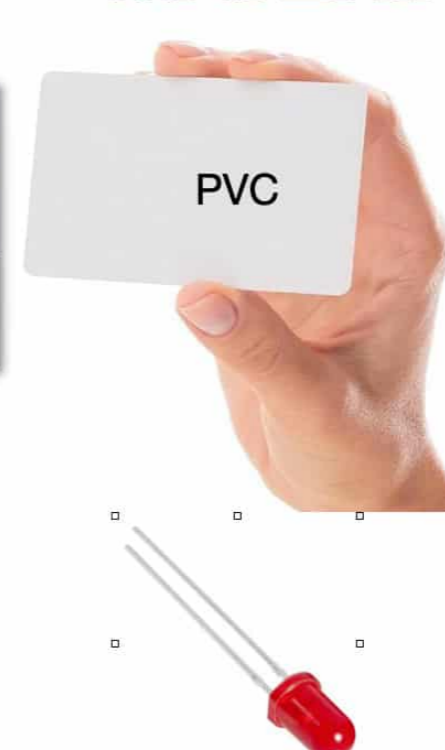

Additionally, Students

- Investigated the different methods of how electricity is created (Nuclear, Fossil Fuels, Hydro and Wind)
- Understood how electrical generators operate.
- Developed Lab Skills in testing strategies, recording data, analysing data and forming conclusions.

Scan for Resources

